

Manual Wheel Balancer

User Manual

INDEX

1—DESCRIPTION OF THE BALANCING MACHINE	2
1.1-GRNERAL	2
1.2-TECHNICAL DATA	2
1.3-USER RECOMMENDATION	2
2—HOISTING AND INSTALLATION	2
2.1--MACHINARY INSTALLMENT	2
2.2--ELECTRIC CONNECTION	2
3—CONTROL PANEL	3
3.1--MEANING OF DISPLY PANEL	3
3.2-- MEANING OF CONTROL PANEL	3
3.3—FUNCTION CONVERSION KEYS	3
4—WHELL MOUNTING	4
4.1--SCREW SPINDLE SCREW ROD INSTALLMENT	4
4.2--TIRE INSTALLMENT	4
5--PRESETTING OF DIMENSIONS	4
6--SELF-CALIBRATION	5
7--WHELL BALANCING	6
7.1--MEASUREMENT OF UNBALANCE	6
7.2--TO MINMIZE STATIC UNBALANCE	6
7.3--STATIC-ALU	6
7.4--SPECIAL “S” FUNCTION	7
8—ERRORS	8
9—ROUTINE MAINTENANCE	9
9.1--TO REPLACE THE FUSES	9
9.2--UNSTABLE BALANCE DISPLAY	9
10--TO CHECK THE DISTANCE GAUGE	9
10.1--THE DISTANCE GAUGE DOES NOT REQUIRE ANY ADJUSTMENT.	9
10.2-- CHECK THE POSITION SENSOR	9
10.3--ASSEMBLY OF THE PIEZO MEASURERS	10
10.4--TECHNICAL DATA SETTING UP	11

1-- DESCRIPTION OF THE BALANCING MACHINE

1.1--GRNERAL

It is an electronic balancing machine with microprocessor designed for balancing wheels weighting up to 65kg. The push button controlled calibration system allows a range of adjustment which is also sufficient to cover wheels

Differing from ordinary ones (motorcycles and racing cars).

Special functions are also available to cater for wheels of unusual shape and there is provision for optional functions of the balancing machine.

1.2--TECHNICALDATA

Max wheel weight	65kg
Balancing accuracy	± 1g
Rim diameter	10" - 24"
Rim width	1.5" - 20"
Cycle time	15s
Net weight	52kg

1.3--RECOMMENDATIONS

- Before starting to use the balancing machine, carefully read the operating instruction manual.
- Keep the manual in a safe place for future reference.
- Refrain from removing or modifying machine parts which would impair correct operation. Please get in touch with the technical service when needing repairs.
- Do not use strong jets of compressed air for cleaning.
- Use alcohol to clean plastic panels or shelves (AVOID LIOUIDS CONTAINING SOLVENTS)
- Before starting the wheel balancing cycle, mark sure that the wheel is securely locked on the adapter.
- The machine operator should not wear clothes with flapping edges; make user that unauthorized personnel do not approach the machine during the work cycle.
- Avoid placing counterweights or other bodies in the base which could impair the correct operation of the balancing machine.
- the balancing machine should not be used for purposes other than those described in the instruction manual.

2--HOISTING AND INSTALLATION

2.1--MACHINARY INSTALLMENT

- 2.1.1 Check parts are in good condition or not. Please contact supplier if any question.
- 2.1.2 Installed on the flat and solid ground, otherwise wrong measurement.
- 2.1.3 500mm around the machine is free for convenient operation.
- 2.1.4 Fasten the machine through the base eyelet .

2.2--ELECTRIC CONNECTION (OPERATED BY SPECIAL PERSONNEL)

- 2.2.1 Select related power supply according to technical data and add to automatic air switch.
- 2.2.2 Select the plug with ground wire. The wire of yellow and green is ground wire, connecting with floor .

The wrong connection will damage the computer.

3--CONTROL PANEL

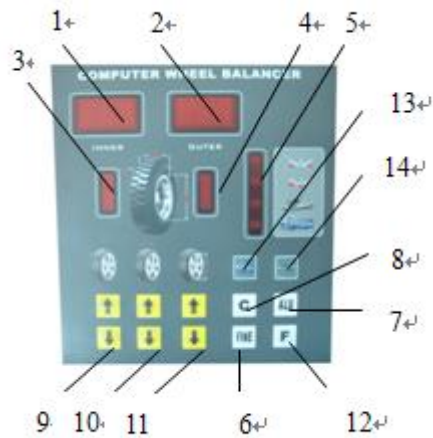

FIG.1

3.1--MEANING OF DISPLY PANEL

1. Digital display, AMOUNT OF UNBALANCE inside
2. Digital display, AMOUNT OF UNBALANCE, outside
3. Indicator, POSITION OF UNBALANCE, inside
4. Indicator, POSITION OF UNBALANCE, outside
5. Indicators, balance mode

3.2-- MEANING OF CONTROL PANEL

6. Push button for reading unbalance < 5g (0.3oz)
7. Push button, balance mode selection
8. Push button for re-calculate:/self-calibration
9. Push buttons a, manual rim DISTANCE input
10. Push buttons b, manual rim WIDTH input
11. Push buttons d, manual rim DIAMETER input
12. Push button, rapid switching between DYNAMIC /STATIC(selection of optional functions)
13. Conversion key of big wheel
14. Conversion key of small wheel

NB: Only use the fingers press the push buttons, NEVER use the pincer for the counter weights or other pointed objects.

3.3--FUNCTION CONVERSION KEYS

3.3.1 PRESETTINGS MEMORIZED ALSO WHEN MACHINE IS SWITCHED OFF:

+ + → -UNIT of measurement of unbalance grams/ounces

3.3.2 PRESETTINGS LOSTED WHEN MACHINE IS SWITCHED OFF:

$\boxed{F} + \boxed{+b} \longrightarrow$ -UNIT of measurement of width mm/inch

$\boxed{F} + \boxed{-b}$ or \longrightarrow (from "PRESETTING OF DIMENSIONS" by selecting WIDTH).

N.B:-In inches each time machine is switched on.

$\boxed{F} + \boxed{+d} \longrightarrow$ -UNIT of measurement of DIAMETER mm/inch

$\boxed{F} + \boxed{-d}$ or \longrightarrow (form "PRESETTING OF DIMENSIONS" by selecting DIAMETER)

N.B:-In inches each time machine is switched on.

3.3.3 DISPLAY OF UNBALANCE:

$\boxed{F} \longrightarrow$ Dynamic \longrightarrow Static \longrightarrow Dynamic

$\boxed{ALU} \longrightarrow S > 1 > 2 > 3 > S$

4--WHEEL MOUNTING

4.1--SPINDLE SCREW ROD INSTALLMENT

Clean the anti-rust with industrial alcohol or gasoline before screw rod mounting to protect installment precision. Screw rod in accessories, aim at the mounting holes, make screw rod and spindle fixed.

4.2--TIRE INSTALLMENT

4.2.1 Mounting the cone which is suitable for rim aperture on the spindle. If the rim is less than "15",the butterfly spring towards outside, then mounting cone and the tire; If the rim is more than "16", doesn't mounting butterfly spring, the smaller side of the cone towards inside, mounting tire and then the cone.

4.2.2 Fasten with quick nut after above all.

5--PRESETTING OF DIMENSIONS

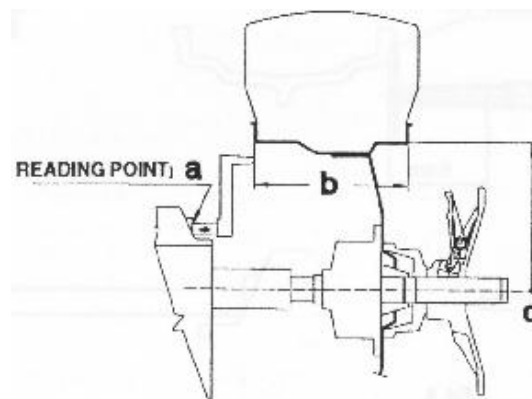

FIG.2

Rim data is stored in the machine. Input data and press [↑] or [↓] to get the right data.

Press distance “a” on the inside of the wheel from the machine measuring it with the special gauge.(Increment pitch 0.5cm. Full scale 26cm)



FIG.3: DISTANCE

Preset the nominal width which is generally given on the rim, or else measure width “b” with the caliper gauge (supplied as standard).

(increment pitches:-unit of measurement mm:5mm

-unit of measurement inch:0.25 " the following is displayed: 0.2 for 1/4 " , 0.5 for 1/2 " , 0.7 for 3/4 ")



FIG.4: WIDTH

Preset the nominal diameter “d” stamped on the type:

(increment pitches:

-unit of measurement mm:12/13mm

-unit of measurement inch:0.5 ")



FIG.5: DIAMETER

6--SELF-CALIBRATION

For machine self-calibration, proceed as follows:

- Mount any wheel on the shaft, even if not balanced; better still if of an “average” size.
- Preset the exact dimensions of the wheel mounted.

CAUTION!! Presetting of incorrect dimensions could mean the machine is not correctly calibrated and therefore all subsequent measurements will be incorrect until a new self-calibration is performed with the correct dimensions!

Display [CAL] [CAL]



FIG.6

Until the full brightness of the unbalanced position indicator stops flashing, release the button. Manual rapid clockwise rotation the spindle, after the indicator is off, stop shaking, until the indicator displayed: [ADD] [100], step down the brake pedal, the spindle stops rotating, outside add 100g (3.5oz) Balanced block, rapid clockwise rotation the spindle again, after the indicator is off, stop shaking, as the indicator is off However, self-calibration can be carried out whenever required or when there is some doubt whether the machine is operating correctly. (fig.6)

7--WHELL BALANCING

7.1-- MEASUREMENT OF UNBALANCE

-To make a measuring spin, close the guard (alternatively press).

-In a few seconds the wheel is brought up to speed and a new braking; the amounts of unbalance remain memorized on instruments 1 and 2.

-The illuminated LED displays show the correct angular position where to fit the counterweights (12o'clock position). Start the breaker and keep it still.

-In this screen, a light pressing of key will display in sequence the preset dimensions.

FIG.7: POSITIONING AND CORRECTION ON THE OUTSIDE

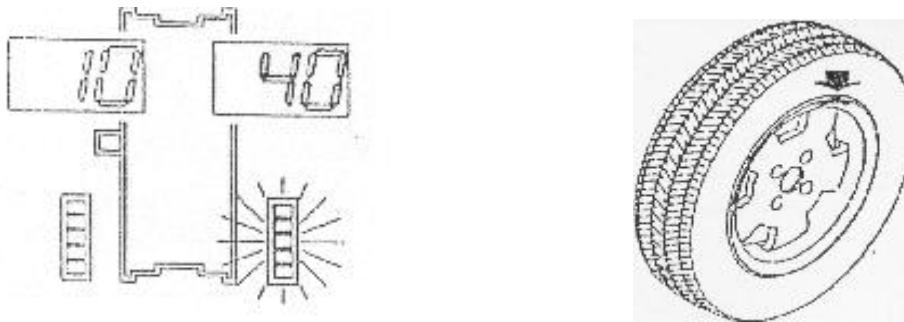
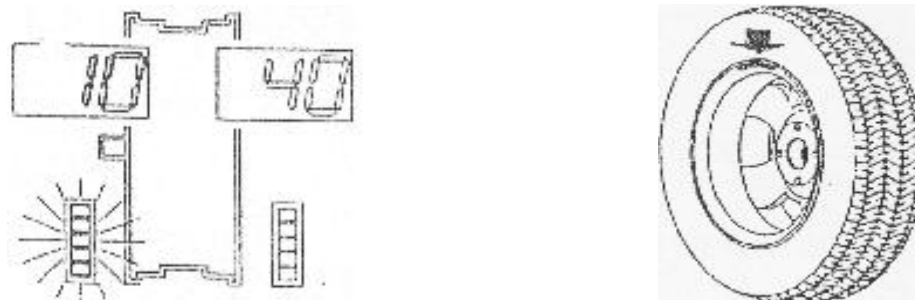

FIG.8: POSITIONING AND CORRECTION ON THE INSIDE



7.2-- TO MINIMIZE STATIC UNBALANCE

-When standard commercially available weights with pitch of 5g every 5g, an unbalance of up to 4g can remain. The damage of such approximation is conspicuous for the fact that most of the disturbances of the vehicle are caused by approximating them in "intelligent" mode according to their position

- Press to display actual unbalance (0-4g)

- The instruments show "0" for unbalance less than 5 grams/0.4 oz to display the residual unbalance, press



7.3--STATIC-ALU

The available functions show where to place the corrective weights in positions differing from the normal ones.

-Press or to select the required function

-The amounts of unbalance are displayed correct on the basis of the selected correction position.



Normal- Balancing of steel or light alloy rims by applying clip-on weights on the rim edges.



Static- STATIC correction is required for motorcycle wheel or when it is not possible to place the counterweights on both sides of the rim.



(ALU)1- Balancing of light alloy rims with application of adhesive wights on the rim shoulders.

(ALU)2- Balancing of alloy rims with hidden application of the outer adhesive weight. Position of the outer weight is the one shown in the figure.



(ALU)3- Combined balancing: clip-on weight on inside; hidden application of the adhesive weight on the outside (Mercedes).

12/13 mm
from rim plane of rest



(Position of the outer weight as in ALU2).

FIG.9

7.4--SPECIAL “S” FUNCTION

The function is used for unusually shaped alloy rims where “ALU2” is not able to guarantee sufficient accuracy.

-Select the S option (relative LED light up) through the [ALU] push button.

-Take note of the dimensions following the diagram given below:

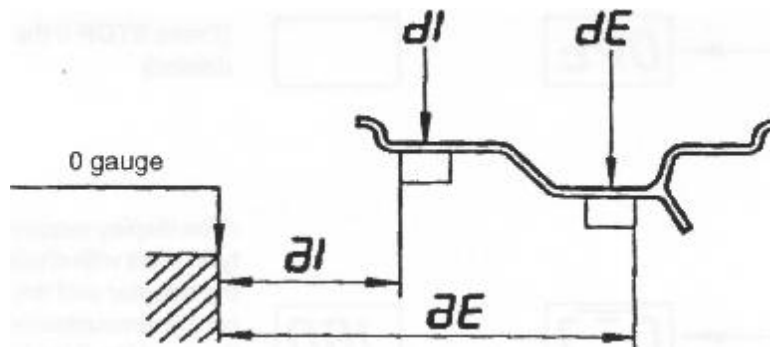
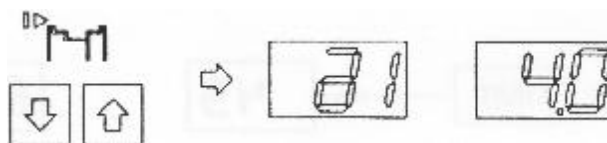

FIG.10

Sequence:



a) To modify al press

“al” The distance between machine body and inside counterweights

“aE” The distance between machine body and outside counterweights

“dl” The diameter dimension of inside counterweights of rim
 “dE” The diameter dimension of outside counterweights of rim

b) To modify aE press

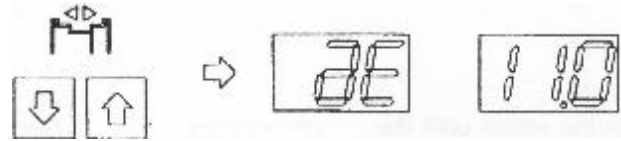

c) To modify dl press

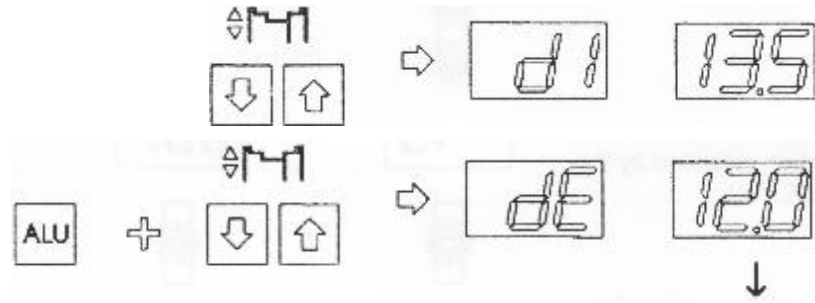

N.B: by default dE is=0.8dl

d) To change dE press
 (keep ALU pressed)

N.B: When dl is reselected, the system automatically returns dE=0.8dl.

The system automatically calculates the distance between the cents of gravity of the weights considering them to be about 14mm wide. To displace the unbalance associated with preset dimensions, press key [C]. if a spin has already been made, the system automatically recalculates the unbalance; otherwise press the [STRAT] key for a new spin.

8--ERRORS

Various abnormal conditions can arise during machine operation. If detected by the microprocessor, they appear on the display, thus:

Err.

—S—

ERROR

MEANING

- | | |
|---|--|
| 1 | No rotation signal. Could be caused by faulty position transducer, or something preventing. |
| 2 | During the measurement spins, wheel speed had dropped to below minimum 60 r.p.m repeat the spin. |
| 3 | Error in mathematical calculations; most probably caused by too high wheel unbalance. |
| 4 | Manual rotation in opposite direction, position sensor wiring errors. |
| 5 | Fault in memory of the self-calibration values. Repeat the self-calibration. |
| 6 | Error during self-calibration. Could be due to the second spin made without adding reference weight, or else by a break in the transducer cable. |

9--ROUTINE MAINTENANCE (Non specialized personnel)

Warning! Before carrying out any operation, disconnect the machine from the mains.

9.1--TO REPLACE THE FUSES

Remove the weight holder shelf to gain access to the power supply PC board and the two fuses mounted on this board. If the fuses require replacement, use ones of the same current rating.

If the failure persists, contact the Technical Service Department.

9.2--UNSTABLE BALANCE DISPLAY

If after balancing, when the wheel is refitted on the vehicle, it is still out-of-balance, this could be due to unbalance of the car brake drum or every due to the holes for the screws of the rim and drum drilled sometimes with too wide tolerances. In such case a readjustment could be advisable using the balancing machine with the wheel mounted.

SPECIAL MAINTENANCE

(Only for specialized personnel)

10--TO CHECK THE DISTANCE GAUGE

10.1--THE DISTANCE GAUGE DOES NOT REQUIRE ANY ADJUSTMENT.

Just be careful when changing the graduated scale. Position it so as to read 0 at the fixed index limit (reading point) when the tip coincides with position shown in the figure.

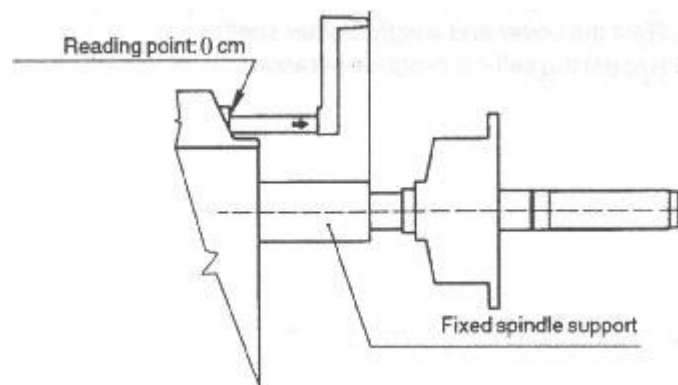

FIG.11

10.2-- CHECK THE POSITION SENSOR

To check efficiency of the position sensor, proceed as follow:

1. Make sure that none of the three photocells rub against the phase disk and RESET tooth.
2. Using a voltmeter set to the Vd.c. scale, test the Following voltages (the machine should be switched

On but without rotation):

*between earth (ground) and red wire +5Vdc steady

*between earth (ground) and yellow wire (RESET) +4.5 to 4.8Vdc when the RESET tooth is in photocell TCST 2000 and "0"Vdc when the RESET tooth is outside the photocell.

*between earth and the green wire (CLOCK) and between earth and the white wire (U/D), when the machine shaft is turned very slowly, there should be a variation in voltage going from "0"Vdc to 4.5/4.8 Vdc.

CAUTION: when the position sensor requires replacement, remove just the PC board after backing-off the two mounting screws; as the mounting bracket is not moved, repositioning is easier.

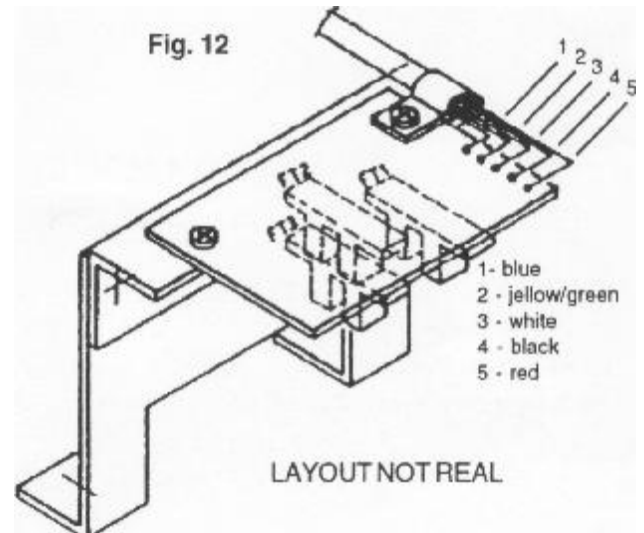

10.3--ASSEMBLY OF THE PIEZO MEASURERS

ASSEMBLY INSTRUCTIONS

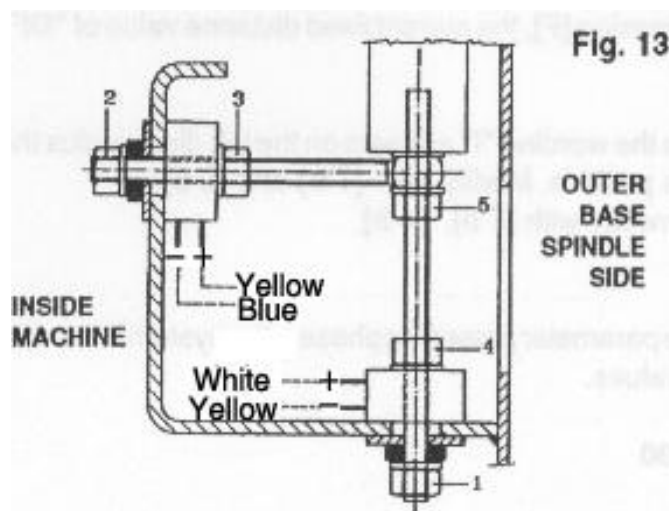

Problems of excessive out-of-phase and compensation, sometimes depend on a fault in the piezo measurers.

To replace them, proceed as follows:

1. Dismounting cover and holder shelf.
 2. Dismounting nuts 1 and 2 with relative cup springs and washers.
 3. Dismounting nuts 3,4, then disassemble the various parts.
 4. Reassemble the various parts without tightening the nuts being careful to follow the correct sequence.
- N.B:** the piezo units should be mounted in according with the position of the coloured wires shown in the drawing.
5. Keeping the spindle perfectly aligned, tighten nut 5 with a spanner and nuts 3 and 4 by hand (plus half a turn with the spanner if necessary).
 6. Refit the cup springs and nuts 1 and 2. Tighten these nuts fully in order to fully regain the elasticity of the cup springs; then loosen them by half a turn. In this way the correct preloading of the piezo will be obtained (a torque wrench can be used set at 400kg.cm).
 7. Cover the piezo units with a generous layer of silicone,

(*N.B.* for correct operation, insulation of the piezo crystals should be greater than 50Mohm).

8. Refit the cover and weight holder shelf.
9. Repeat the self-calibration operation.

10.4-- TECHNICAL DATA SETTING UP

The correct technical data makes sure the wheel balance precision.

Press {F}+{C}, and then press the keys according to the following steps within 5 seconds when the light begins to shine. {-a}---{+a}----{F}.

When you press {-a} and {+a}, the display screen will disappear.

Press {F}, the present distance data will be on.

{DF} {125}, the right data is {DF}, Press {+b} and {b} to change the data {DF}.

Press {+a} to shift data "I"

When {I} and {-3} are displayed, Data "I" is displayed on the right side. Press {+a} to shift data "S"

When {S} and {330} are displayed, press {+b} and {-b} to change data "S", and then press {+a} to conclude the operation.